



SMD Type 1500 W

■ Features

1. Glass passivated chip
2. 1500W peak pulse power capability at 10/1000 μ s waveform, repetition rate (duty cycle): 0.01%
3. Excellent clamping capability
4. Very fast response time
5. Low clamping voltage
6. Low leakage current
7. Meets MSL level 1, per J-STD-020 LF maximum peak of 260°C
8. Halogen free and RoHS compliant
9. AEC-Q101 qualified



■ Recommended Applications

1. I/O interface
2. AC/DC power supply
3. Low frequency signal transmission line

■ Mechanical Data

1. Case: DO-214AB (SMC), molded plastic meets
2. Epoxy : UL 94V-0 rate flame retardant
3. Terminal: Solderable per MIL-STD-750, Method 2026
4. Polarity: Color band denotes cathode end
5. Mounting Position: Any

■ Part Number Code

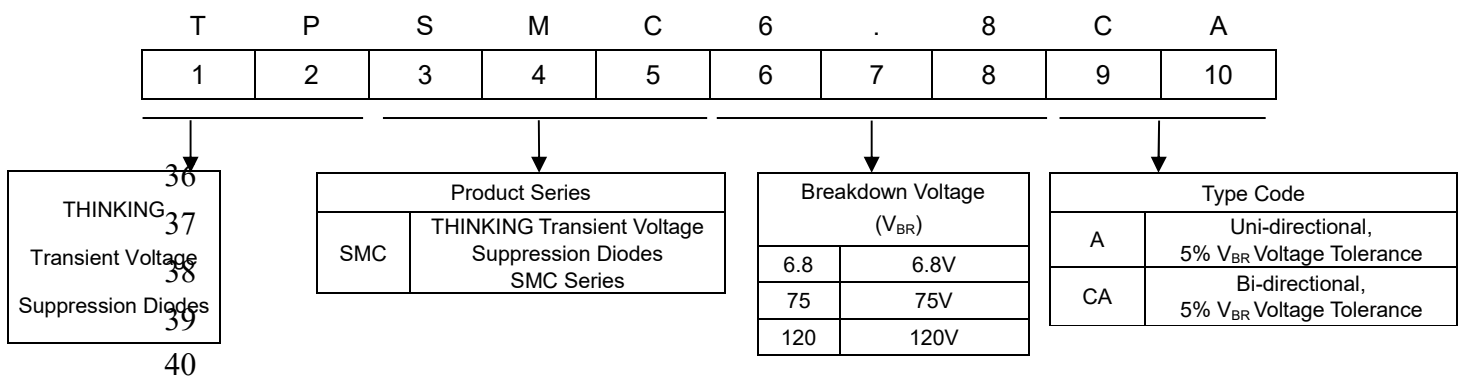

SMD Type 1500 W

Structures and Dimensions

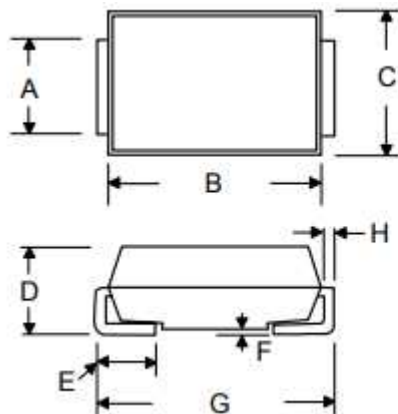

Symbol	Dimensions in millimeters	
	Min	Max
A	2.90	3.20
B	6.60	7.11
C	5.59	6.22
D	2.06	2.62
E	0.76	1.52
F	-	0.20
G	7.75	8.13
H	0.15	0.31

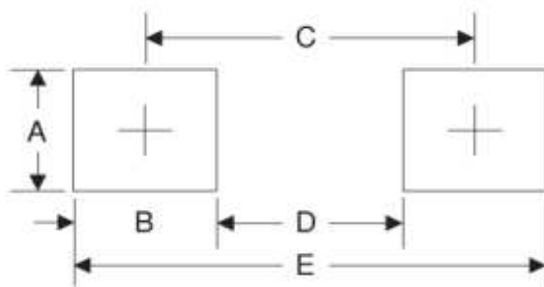

Symbol	Unit (mm)	Unit (inch)
A	3.30	0.130
B	2.50	0.098
C	6.80	0.268
D	4.40	0.173
E	9.40	0.370

Maximum Rating ($T_A=25^\circ\text{C}$ unless otherwise noted)

Parameter	Symbol	Value	Unit
Peak power dissipation with a 10/1000 μs waveform (Note 1,2)	P_{PPM}	1500	W
Peak pulse current with 10/1000 μs waveform (Note 1)	I_{PPM}	See next table	A
Peak forward surge current, 8.3 ms single half sine-wave (Note 3)	I_{FSM}	200	A
Power dissipation on infinite heatsink at $T_L=75^\circ\text{C}$	PD	6.5	W
Typical thermal resistance junction to ambient	$R_{\theta JA}$	75	$^\circ\text{C} / \text{W}$
Typical thermal resistance junction to lead	$R_{\theta JL}$	15	$^\circ\text{C} / \text{W}$
Operating junction and storage temperature range	T_J, T_{STG}	-55~+150	$^\circ\text{C}$

Notes : (1) Non-repetitive current pulse, per Fig. 3 and derated above $T_A=25^\circ\text{C}$ per Fig. 2

(2) Mounted on copper pad area of 8.0 x 8.0mm to each terminal

(3) Measured on 8.3ms single half sine wave or equivalent square wave for unidirectional device only, duty cycle=4 per minute maximum



SMD Type 1500 W

■ Electrical Characteristics (T_A=25°C unless otherwise noted)

Part No. (Uni)	Part No. (Bi)	Reverse Stand off Voltage	Breakage Voltage VBR @ IT		Test Current	Maximum Clamping Voltage VC @ Ipp	Maximum Peak Pulse Current	Maximum Reverse Leakage IR @VRWM	Marking Code	
			VRWM (V)	Min(V)					Max(V)	IT(mA)
TPSMC6.8A	TPSMC6.8CA	5.8	6.45	7.14	10	10.5	144.8	1000	6V8A	6V8C
TPSMC7.5A	TPSMC7.5CA	6.4	7.13	7.88	10	11.3	134.5	500	7V5A	7V5C
TPSMC8.2A	TPSMC8.2CA	7.02	7.79	8.61	10	12.1	125.6	200	8V2A	8V2C
TPSMC9.1A	TPSMC9.1CA	7.78	8.65	9.55	1	13.4	113.4	50	9V1A	9V1C
TPSMC10A	TPSMC10CA	8.55	9.5	10.5	1	14.5	104.8	10	10A	10C
TPSMC11A	TPSMC11CA	9.4	10.5	11.6	1	15.6	97.4	5	11A	11C
TPSMC12A	TPSMC12CA	10.2	11.4	12.6	1	16.7	91	5	12A	12C
TPSMC13A	TPSMC13CA	11.1	12.4	13.7	1	18.2	83.5	5	13A	13C
TPSMC15A	TPSMC15CA	12.8	14.3	15.8	1	21.2	71.7	1	15A	15C
TPSMC16A	TPSMC16CA	13.6	15.2	16.8	1	22.5	67.6	1	16A	16C
TPSMC18A	TPSMC18CA	15.3	17.1	18.9	1	25.2	60.3	1	18A	18C
TPSMC20A	TPSMC20CA	17.1	19	21	1	27.7	54.9	1	20A	20C
TPSMC22A	TPSMC22CA	18.8	20.9	23.1	1	30.6	49.7	1	22A	22C
TPSMC24A	TPSMC24CA	20.5	22.8	25.2	1	33.2	45.8	1	24A	24C
TPSMC27A	TPSMC27CA	23.1	25.7	28.4	1	37.5	40.5	1	27A	27C
TPSMC30A	TPSMC30CA	25.6	28.5	31.5	1	41.4	36.7	1	30A	30C
TPSMC33A	TPSMC33CA	28.2	31.4	34.7	1	45.7	33.3	1	33A	33C
TPSMC36A	TPSMC36CA	30.8	34.2	37.8	1	49.9	30.5	1	36A	36C
TPSMC39A	TPSMC39CA	33.3	37.1	41	1	53.9	28.2	1	39A	39C
TPSMC43A	TPSMC43CA	36.8	40.9	45.2	1	59.3	25.6	1	43A	43C
TPSMC47A	TPSMC47CA	40.2	44.7	49.4	1	64.8	23.5	1	47A	47C
TPSMC51A	TPSMC51CA	43.6	48.5	53.6	1	70.1	21.7	1	51A	51C
TPSMC56A	TPSMC56CA	47.8	53.2	58.8	1	77	18.7	1	56A	56C
TPSMC62A	TPSMC62CA	53	58.9	65.1	1	85	17.9	1	62A	62C
TPSMC68A	TPSMC68CA	58.1	64.6	71.4	1	92	16.5	1	68A	68C
TPSMC75A	TPSMC75CA	64.1	71.3	78.8	1	103	14.8	1	75A	75C
TPSMC82A	TPSMC82CA	70.1	77.9	86.1	1	113	13.5	1	82A	82C
TPSMC91A	TPSMC91CA	77.8	86.5	95.5	1	125	12.2	1	91A	91C
TPSMC100A	TPSMC100CA	85.5	95	105	1	137	11.1	1	100A	100C



SMD Type 1500 W

■ Electrical Characteristics ($T_A=25^\circ\text{C}$ unless otherwise noted)

Part No. (Uni)	Part No. (Bi)	Reverse Stand off Voltage	Breakage Voltage VBR @ IT		Test Current	Maximum Clamping Voltage VC @ Ipp	Maximum Peak Pulse Current	Maximum Reverse Leakage IR @VRWM	Marking Code	
			VRWM (V)	Min(V)					Max(V)	IT(mA)
TPSMC110A	TPSMC110CA	94	105	116	1	152	10	1	110A	110C
TPSMC120A	TPSMC120CA	102	114	126	1	165	9.2	1	120A	120C
TPSMC130A	TPSMC130CA	111	124	137	1	179	8.5	1	130A	130C
TPSMC150A	TPSMC150CA	128	143	158	1	207	7.3	1	150A	150C
TPSMC160A	TPSMC160CA	136	152	168	1	219	6.9	1	160A	160C
TPSMC170A	TPSMC170CA	145	162	179	1	234	6.5	1	170A	170C
TPSMC180A	TPSMC180CA	154	171	189	1	246	6.2	1	180A	180C
TPSMC200A	TPSMC200CA	171	190	210	1	274	5.5	1	200A	200C
TPSMC220A	TPSMC220CA	185	209	231	1	328	4.6	1	220A	220C
TPSMC250A	TPSMC250CA	214	237	263	1	344	4.4	1	250A	250C
TPSMC300A	TPSMC300CA	256	285	315	1	414	3.7	1	300A	300C
TPSMC350A	TPSMC350CA	300	333	368	1	482	3.2	1	350A	350C
TPSMC400A	TPSMC400CA	342	380	420	1	548	2.8	1	400A	400C
TPSMC440A	TPSMC440CA	376	418	462	1	602	2.5	1	440A	440C
TPSMC480A	TPSMC480CA	408	456	504	1	658	2.3	1	480A	480C
TPSMC510A	TPSMC510CA	434	485	535	1	698	2.1	1	510A	510C
TPSMC530A	TPSMC530CA	450	503	556	1	725	2.1	1	530A	530C
TPSMC540A	TPSMC540CA	459	513	567	1	740	2	1	540A	540C

SMD Type 1500 W

■ Rate and Characteristic Curve ($T_A=25^\circ\text{C}$ unless otherwise noted)

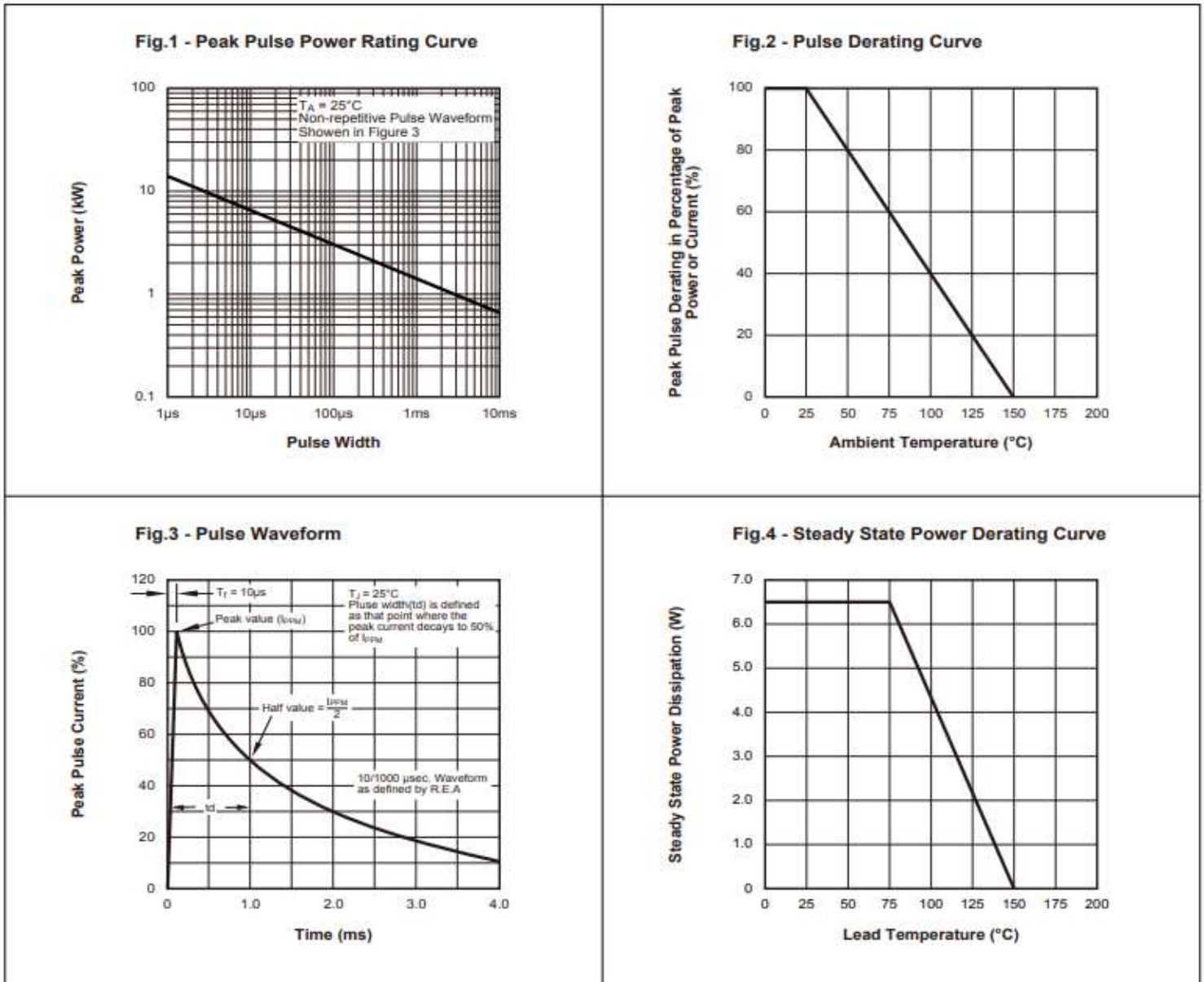

IR-reflow soldering profile

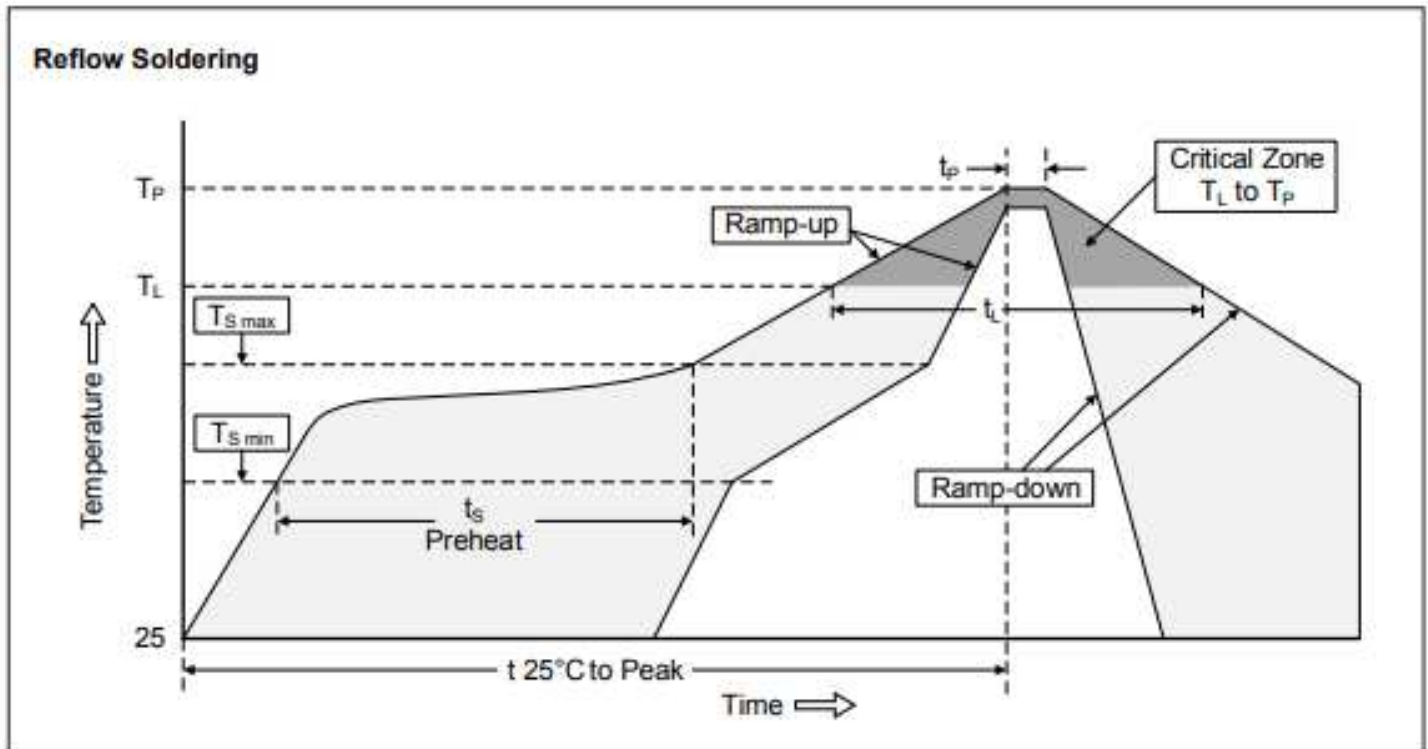

Recommended Conditions

Profile Feature	Pb-Free Assembly
Average ramp-up rate (T_L to T_P)	3°C/second max.
Preheat	
- Temperature Min ($T_{S\ min}$)	150°C
- Temperature Max ($T_{S\ max}$)	200°C
- Time (min to max) (t_S)	60-180 seconds
$T_{S\ max}$ to T_L	
- Ramp-up Rate	3°C/second max.
Time maintained above:	
- Temperature (T_L)	217°C
- Time (t_L)	60-150 seconds
Peak Temperature (T_P)	260°C
Time within 5°C of actual Peak Temperature (t_P)	20-40 seconds
Ramp-down Rate	6°C/second max.
Time 25°C to Peak Temperature	8 minutes max.

Transient Voltage Suppression Diodes: TPSCM Series

SMD Type 1500 W



■ Packaging

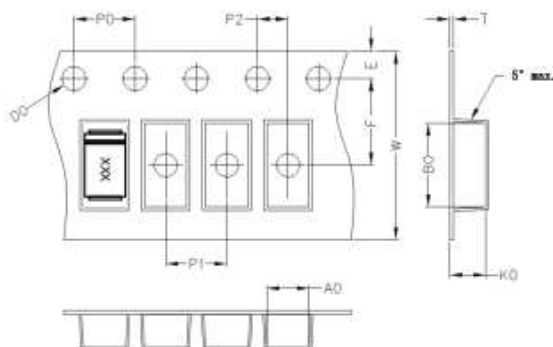

A0	B0	K0	D0	E	F
6.05	8.31	2.54	1.55	1.75	7.50
P0	P1	P2	T	W	Tolerance
4.0	8.0	2.0	0.25	16	0.1

■ Quantity

Series Type	Packaging option	Base quantity	Packaging specification
TPSCM	Tape and reel	3000/reel	EIA STD RS-481

■ Warehouse Storage Conditions of product

- Storage Condition:
 1. Storage Temperature: $\leq 25^{\circ}\text{C}$
 2. Relative Humidity: 50%~80%RH
 3. Keep away from corrosive atmosphere and sunlight.
- Period of Storage: 1 year.